



FG PUMPS

METERING PUMPS FOR
CHEMICALS

**INSTRUCTIONS MANUAL
FOR CONTROLLERS SERIES**

D100, D200, D300



ALLIGUARD

WATER TREATMENT SOLUTIONS

Lasithiou 77, Glyfada Athens, Greece 16674

M: 6947 810 227 • 6906 185 915 / E: grakanidis@alliguard.gr

www.alliguard.gr



FUGI S.R.L. – Cap. Soc. € 10.400,00 i.v.
Via Bruno Buozzi 23/27 - 20054 Segrate (MI) – ITALY
Tel +39 022139334 Fax +39 0226921365
www.fugi.it – info@fugi.it
P.IVA e Cod. Fisc. 12714360158 – REA 1579510

Owner of  brand – www.fgpumps.com

DECLARATION OF CONFORMITY



FUGI S.R.L. company,

- with operational headquarters in via Buozzi 23-27, Segrate;
- owner of the FG PUMPS trademark, registered with the C.C.I.A.A of Milan;

Hereby declares that the products named

- FGS K, FGS P, FGS M, FGS PH, FGS CL, FGS D100, FGS D200, FGS D300, FGS DIN, FGS RACK

Responds to the principal features of the following European Directives:

- 2014/30/CE of 26.02.2014 – *Harmonization of the laws of the Member States relating to electromagnetic compatibility – EMC Directive*
- 2014/35/CE of 26.02.2014 – *Harmonization of the laws of the Member States relating to the making available on the market of electrical equipment designed for use within certain voltage limits – Low Voltage Directive*
- 2011/65/UE of 08.06.2011 with subsequent update 2015/863 of 31.03.2015 – *ROHS III Directives*
- 2012/19/UE of 04.07.2012 – *WEEE Directives for electrical and electronic waste*

This declaration is issued under the responsibility of FUGI S.R.L.

F.CIUFFI – FUGI SRL

A handwritten signature in blue ink, appearing to be 'F. Ciuffi', is written over a faint, larger version of the signature.

INDEX

1. GENERAL RULES	38
1.1 INSTALLATION STANDARDS	38
2. OPERATION	39
2.1 OVERALL DIMENSIONS	39
2.2 TECHNICAL FEATURES.....	39
2.3 CONTENT OF THE PACKAGE	39
3. D100, D200, D300 CONTROLLERS	Errore. Il segnalibro non è definito.
3.1 UNIT CONTROLS	40
3.2 INPUT AND OUTPUT ARRANGEMET.....	40
3.3 TERMINAL BLOCKS CONNECTION	43
3.4 START-UP THE CONTROLLER	44
3.5 HOW TO NAVIGATE THROUGH THE MENUS.....	46
3.6 METER SETUP	47
3.6.1 SETPOINT menu (BASIC menu).....	48
3.6.2 SETPOINT menu (ADVANCED menu)	49
3.6.3 SETPOINT menu Temperature (ADVANCED menu).....	50
3.6.4 CALIBRATION menu	51
3.7 CORRELATION BETWEEN FREE CHLORINE, pH e REDOX	54
3.8 GENERAL / ADVANCED SETTINGS and SECURITY.....	55
3.8.1 General > Proximity sensor	56
3.8.2 General > Temperatura manuale.....	56
3.8.3 General > Energy saving	57
3.8.4 Advanced > Channel measurement settings.....	58
3.8.5 Advanced > pH priority.....	59
3.8.6 Advanced > Stabilization time.....	59
3.8.7 Advanced > mA Output.....	60
3.8.8 Advanced > Temperature sensor	61
3.8.9 Advanced > Auxiliary Output (AUX).....	61
3.8.10 Advanced > RS485 serial interface	63
3.8.11 Security > Low Level Delay	64
3.8.12 Security > Level Input Polarity	65
3.8.13 Security > Minimum / Maximum value alarm	65
3.8.14 Security > (OFA) Over Feed Alarm.....	66
3.8.15 Security > Password	66
3.8.16 Security > Factory Settings restore.....	67
3.9 STATISTICS.....	68
3.10 WARRANTY.....	68
TABELLA RIEPILOGATIVA FUNZIONI / FUNCTION SUMMARY TABLE	69

1. GENERAL RULES

Carefully read the warnings listed below as they provide important information regarding the rules for installation, use and maintenance.

Please keep this manual carefully for further reference.

1.1 INSTALLATION STANDARDS

The controller must always be accessible both during operation and during maintenance. Access must not be blocked in any way!

All connection operations must be performed while the controller is not connected to the main power supply!

The controller must be used / repaired only by qualified technicians!

In case of emergency the controller must be turned off immediately! Disconnect the power cable!

Fugi Srl cannot be held responsible for damage to people and / or things caused by bad installation or incorrect use of the instrument.



THE EQUIPMENT, SUBJECT TO THIS DOCUMENT, ARE NOT INTENDED TO BE INSTALLED AND USED IN EXPLOSIVE ATMOSPHERE ENVIRONMENTS. IT ISN'T AN ATEX DEVICE.

2. OPERATION

The new range of controllers are digital microprocessor devices which allow you to constantly monitor and regulate all the chemical-physical parameters that the water to be treated has. In particular, the instrument detects: pH, Redox, Chlorine, Conductivity and Temperature. Particular attention has been paid to making the use of these units user friendly thanks to a large graphic display and a digital encoder that allow you to navigate the various configuration menus.

2.1 OVERALL DIMENSIONS

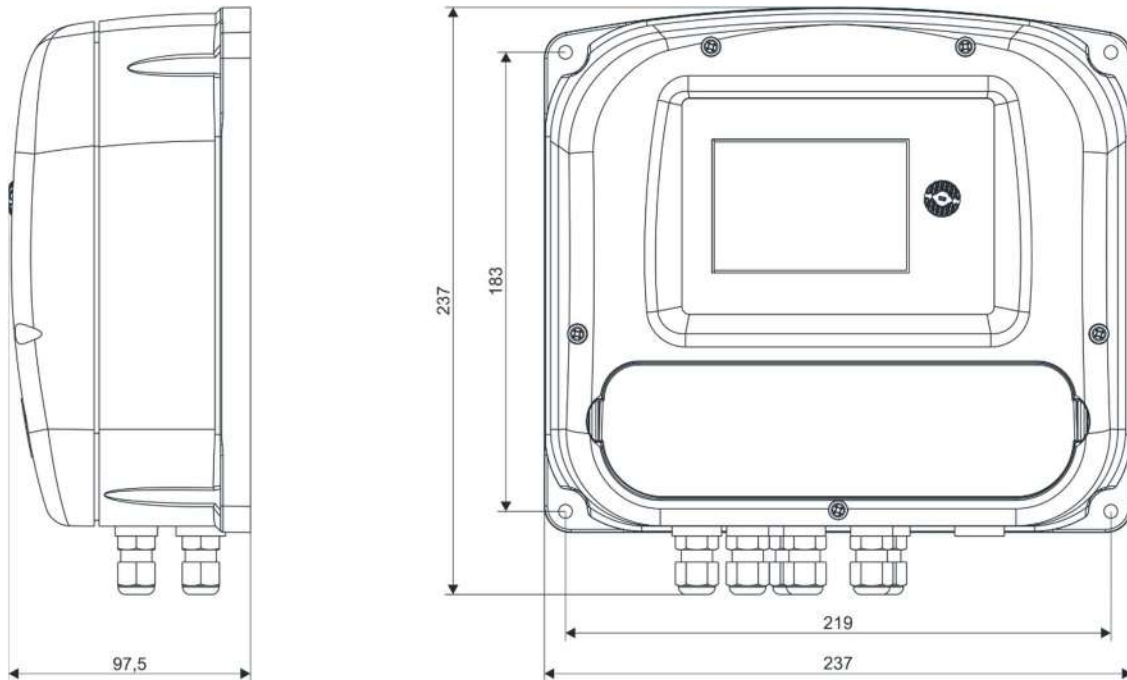

2.2 TECHNICAL FEATURES

Power supply:	100÷240VAC ± 10% – 50/60Hz
Insulation Class:	CLASS II
Absorbed power:	5 Watt
Operating ranges::	pH: 0÷14 / Redox: 0÷ ±2000mV / CL: 0÷ ±2000mV o 0÷2000 ppm
Protection Grade:	IP55
Environmental conditions:	Closed environment, altitude up to 2000m, room temperature from 5°C up to 40°C, maximum relative humidity 80% (linearly decreases until it is reduced to 50% at 40°C).

2.3 CONTENT OF THE PACKAGE

- D100, D200, D300
- User's manual
- Set of screws and plugs for wall mounting

Installation kit available upon request:

- Wall fixing bracket and bracket adaptor (cod. FGSP6020311).

3. D100, D200, D300 CONTROLLER SERIES

3.1 UNIT CONTROLS

The control panel consists of a graphic display (1) and an encoder knob (2) which allow you to navigate through the various menus and select / modify the configuration parameters.

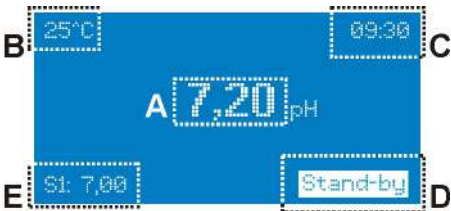

- A. Value read;
- B. Temperature value;
- C. Time;
- D. Warning messages;
- E. Setpoint

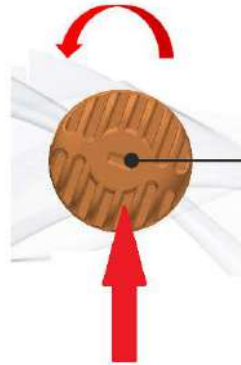

Press to: confirm a value or access a submenu. If it is kept pressed, it returns to the previous menu or activates / deactivates Stand-by (only from the main screen).

Rotate to: navigate the menus or change a numeric value.

3.2 INPUT AND OUTPUT ARRANGEMENT

Disconnect the controller from the main power supply, then remove the front protective cover with the help of a screwdriver (use the image below to identify the lid opening points), identify the various outputs / inputs and make the connections following the next images:



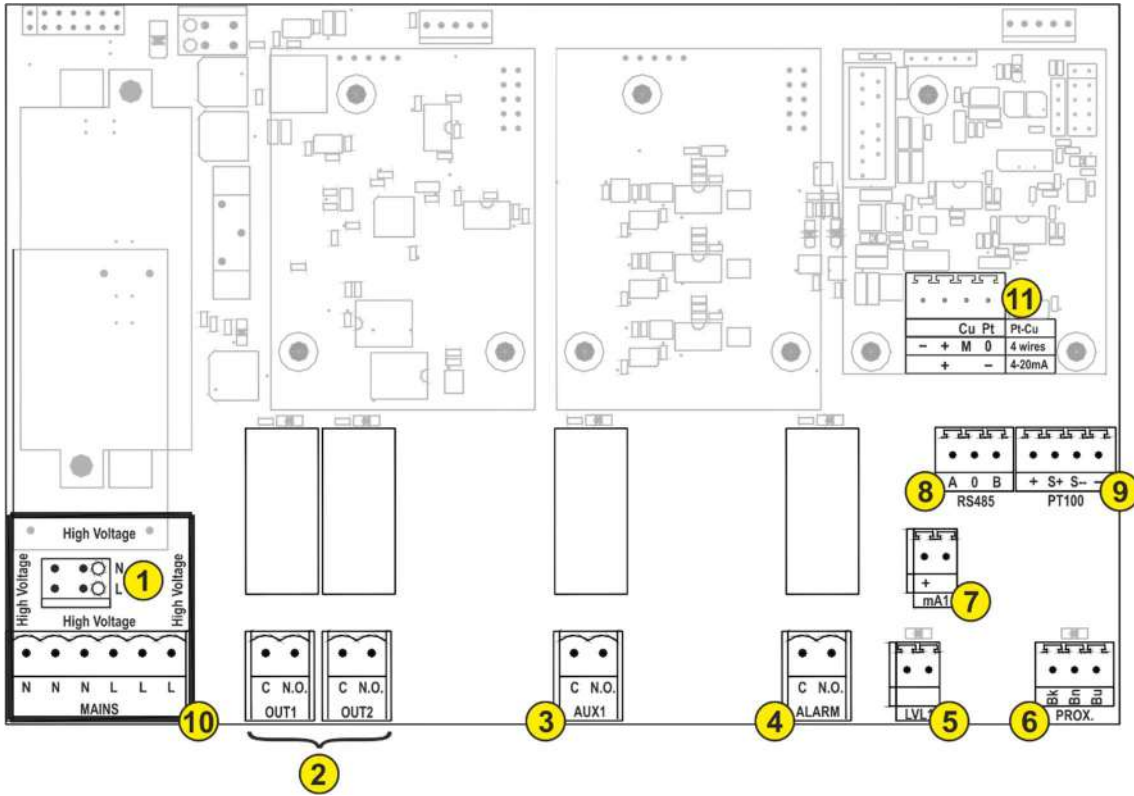

TWO MEASURES CONFIGURATION

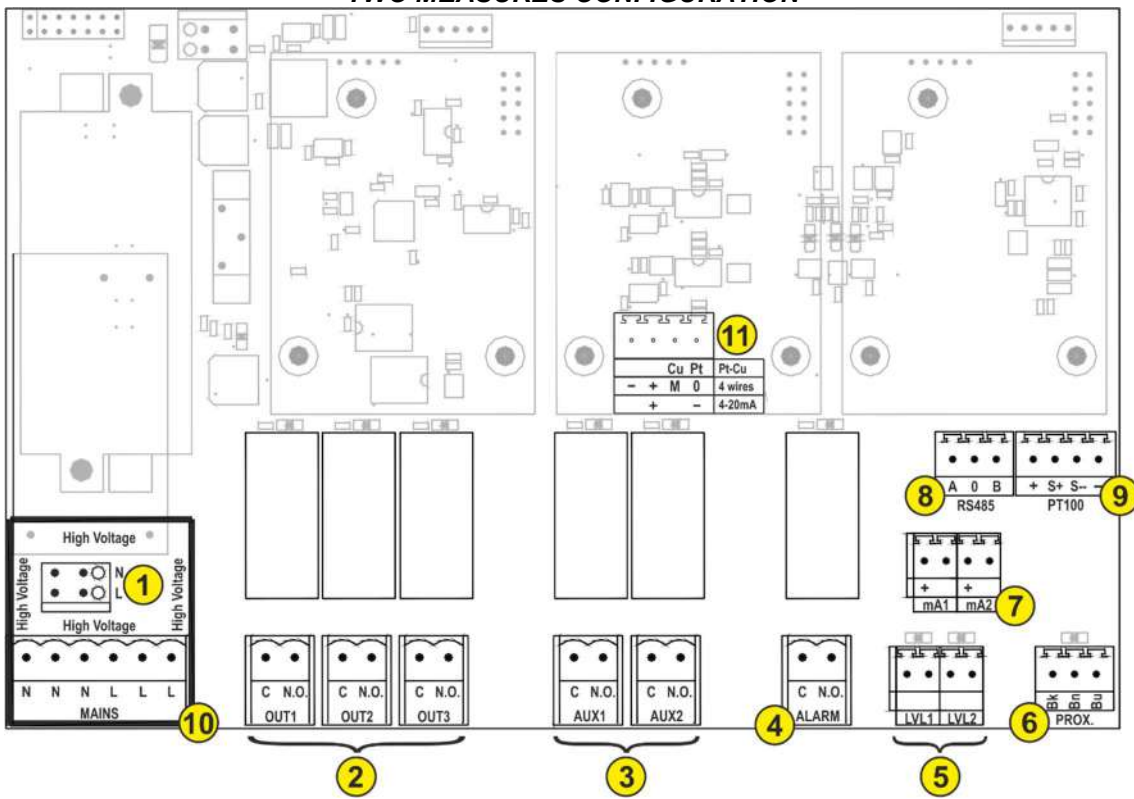

THREE MEASURES CONFIGURATION

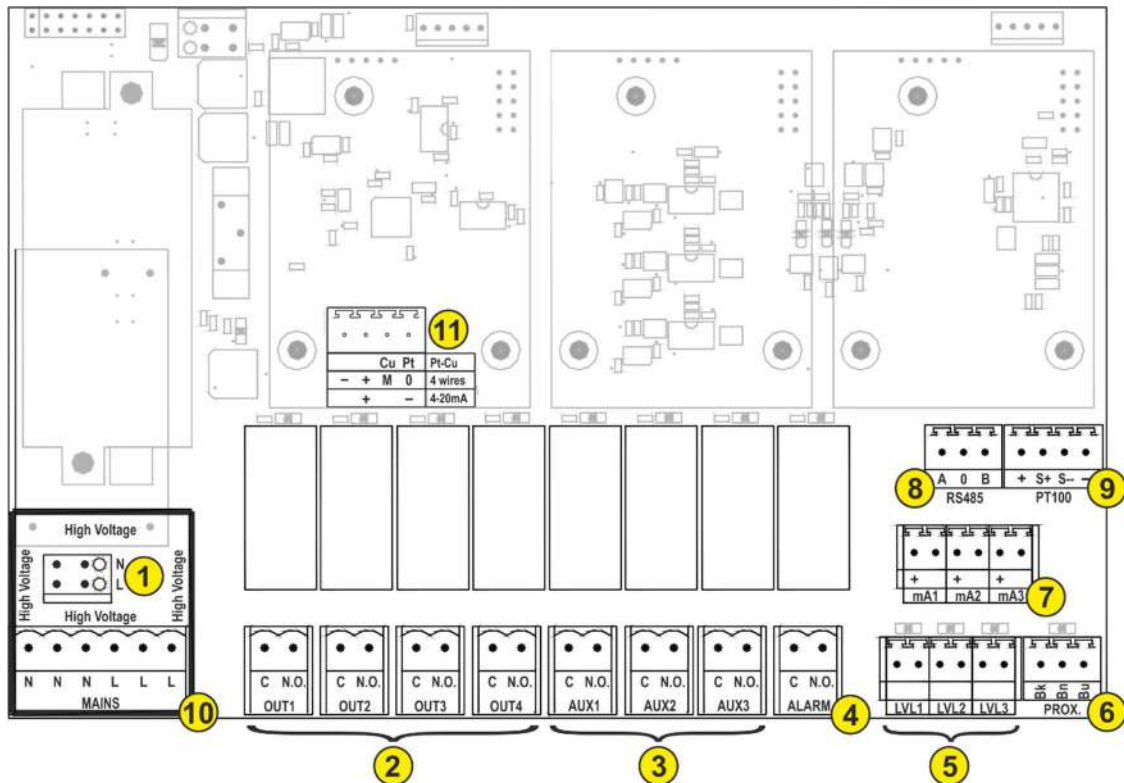

12. Main power supply 100=240Vac 50/60Hz;

13. **Output Relays OUT (from 1 to 4):** max resistive load 5A @ 240V for the connection of up to 4 metering pumps or 4 ON-OFF units;

14. **Auxiliary Relays AUX (from 1 to 3):** max resistive load 5A @ 240V for **FLOCCULANT** or **CLEANING** function (Pt-Cu cell cleaning) or to set a **Temperature Setpoint**;

15. **ALARM:** Alarm Relay (max resistive load 5A @ 240V) for visual or audible signaling;

16. **Level probes LVL:** connection of up to 3 level probes (**one for each measurement channel**);

17. **PROX.:** proximity sensor input to monitor the presence of water;

18. **mA outputs:** max resistive load 500 Ohm, (**one for each measurement channel**);

19. **RS485:** connection to a device that uses the **RS485 protocol**;

20. **PT100:** 3 or 4 wires **PT100 temperature sensor**;

21. **MAINS:** terminal block for internal wiring of pumps or ON-OFF devices;

22. **CL:** Terminal block for connecting three different types of probes for **chlorine** measurement

The inputs and outputs of the controller are related to the measurement channels (CH), a two-measurement controller will have 2 measurement channels (CH1 and CH2), a three-measurement controller will have 3 measurement channels (CH1, CH2 and CH3), the single-measure controller will obviously have only one channel (CH1):

1-measure instrument:

CH1: OUT1 and OUT 2; LVL1 and mA1;

2-measure instrument:

CH1: OUT1 e OUT 2; LVL1; mA1;

CH2: OUT 3; LVL2; mA2;

3-measure instrument:

CH1: OUT1 e OUT 2; LVL1; mA1;

CH2: OUT 3; LVL2; mA2;

CH3: OUT 4; LVL3; ma3

3.3 TERMINAL BLOCKS CONNECTION

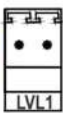
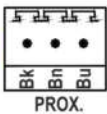
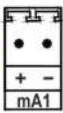
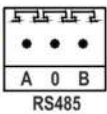
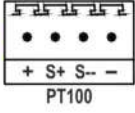
5		Level probe: connect the two poles
6		Proximity sensor: Bk : Black wire (+) Bn : Brown wire (+12Vdc) Bu : Blue wire (--)
7		4-20mA output: +: positive -: negative
8		RS485 interface A : + 0 : Ground B : --
9		3 wires PT100 temperature sensor: + : White wire S+ : jumper with + S-- : Red wire -- : Red wire

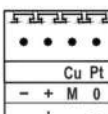
11		Pt-Cu probe: blue wire (Cu) brown wire (Pt)
		4 wires chlorine probe: brown wire (--) green wire (+) white wire (M) yellow wire (0)
		4-20mA chlorine probe: blue wire (--) brown wire (+)

Chlorine probes connections

Example of connection of a constant dosing pump (ON-OFF) to the controller terminal blocks

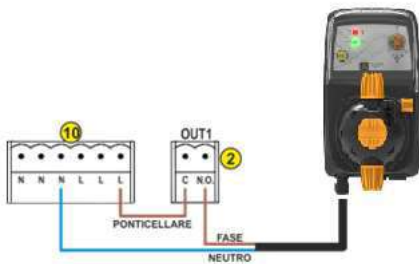

Example of connection of a volumetric dosing pump (mA) to the controller terminal blocks

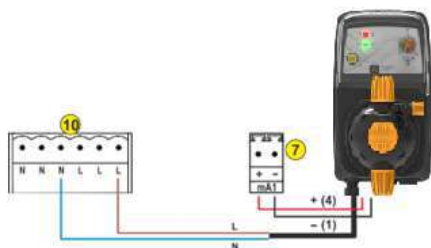

3.4 START-UP THE CONTROLLER

The first time the controller is turned on, you are asked to set some essential parameters for correct operation: the control unit has two programming menus, **BASIC** and **ADVANCED** (for expert users).

Below is a diagram of what appears the first time the unit is turned on by setting the menus in **BASIC** mode:

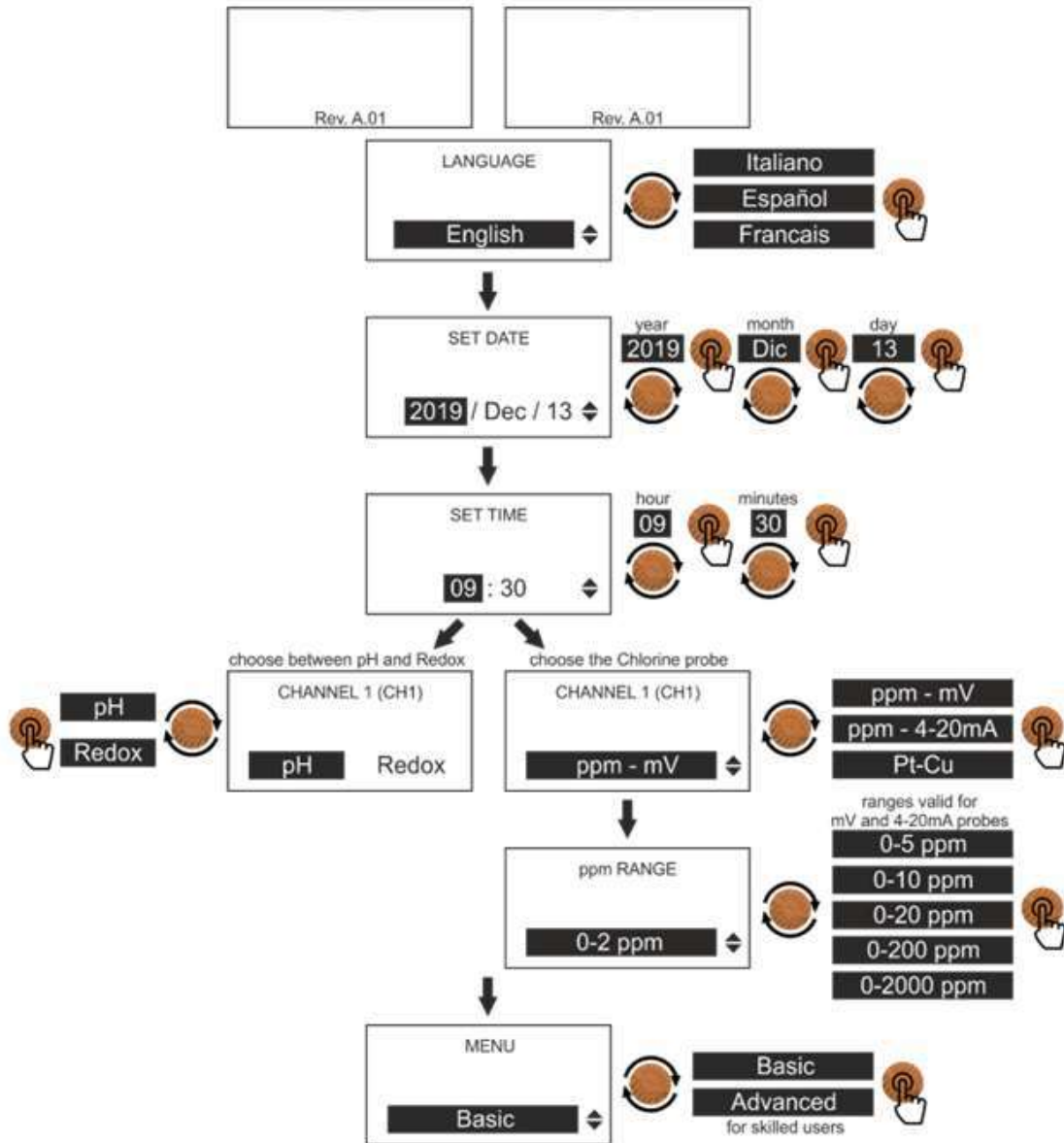

If you choose the **ADVANCED** menu you are asked to set further parameters:

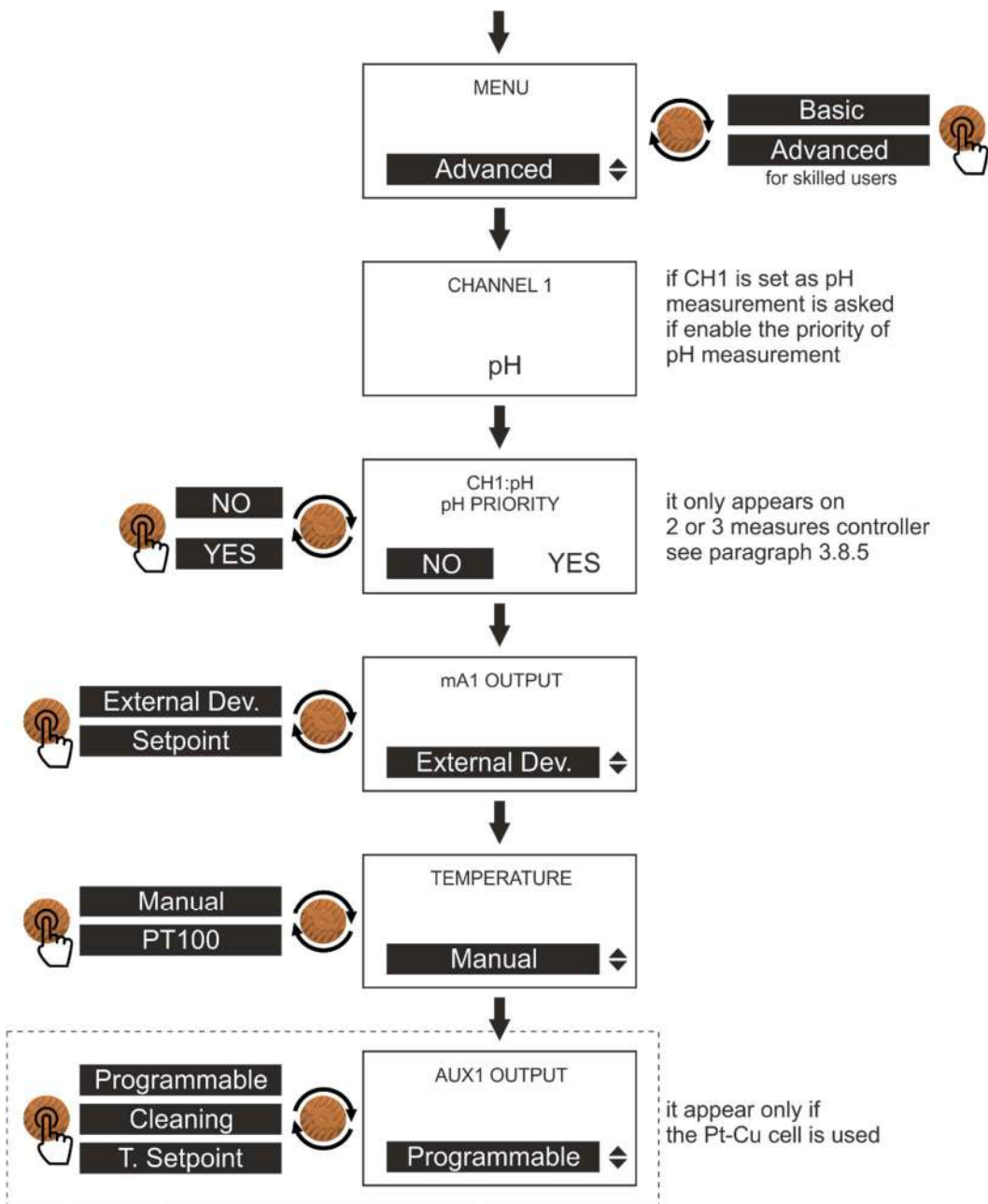

3.5 HOW TO NAVIGATE THROUGH THE MENUS

The range of controllers have been designed so that the programming steps are user friendly, for this reason the control area has a large backlit graphic display and a rotary encoder with integrated button function.

A navigation diagram of the menus on the pump is shown below:

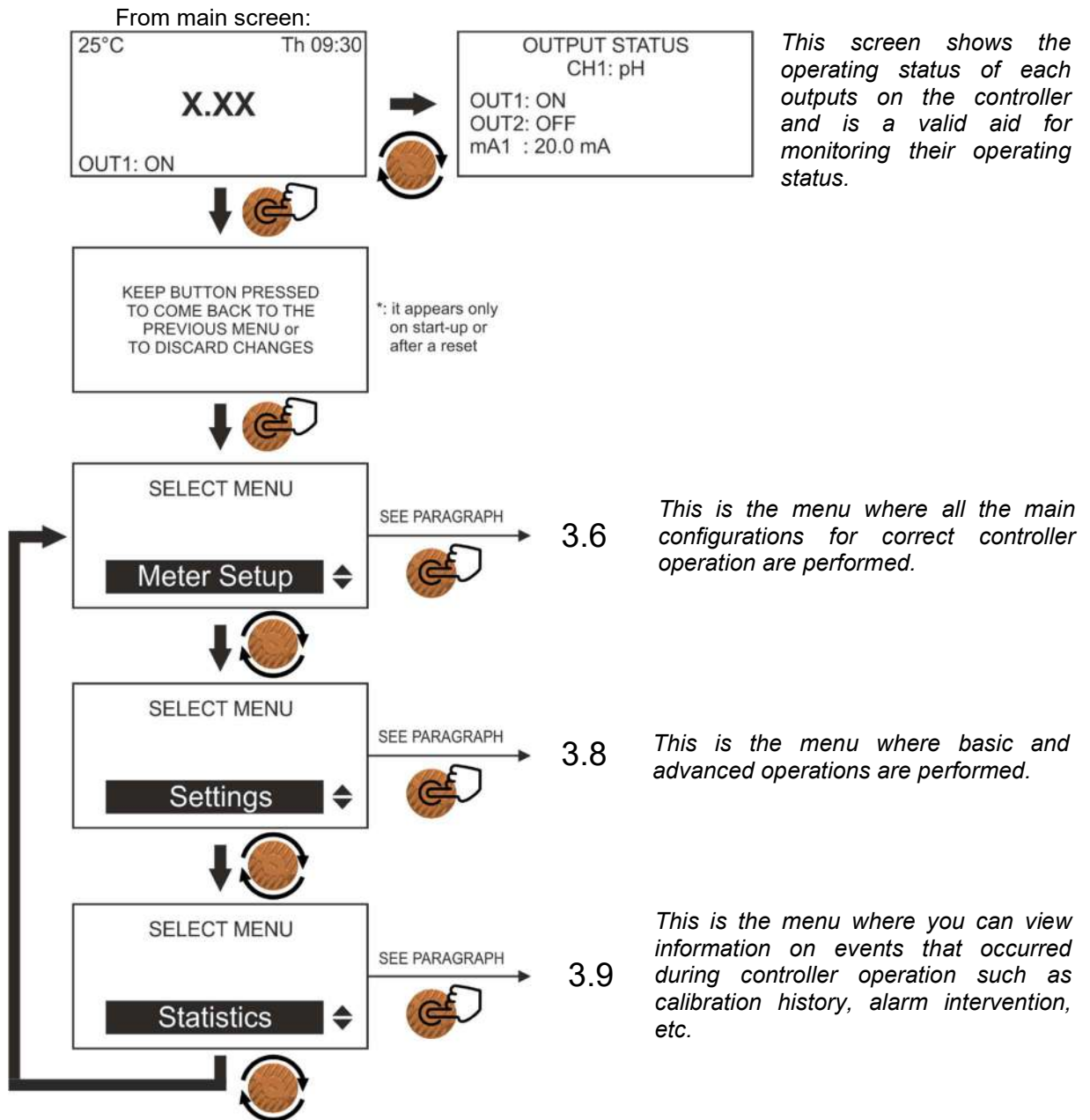

3.6 METER SETUP

Within this menu, it is possible to choose the working point (setpoint) and the operating mode or carry out the calibration of the probes.

The complete list of available functions is shown below:

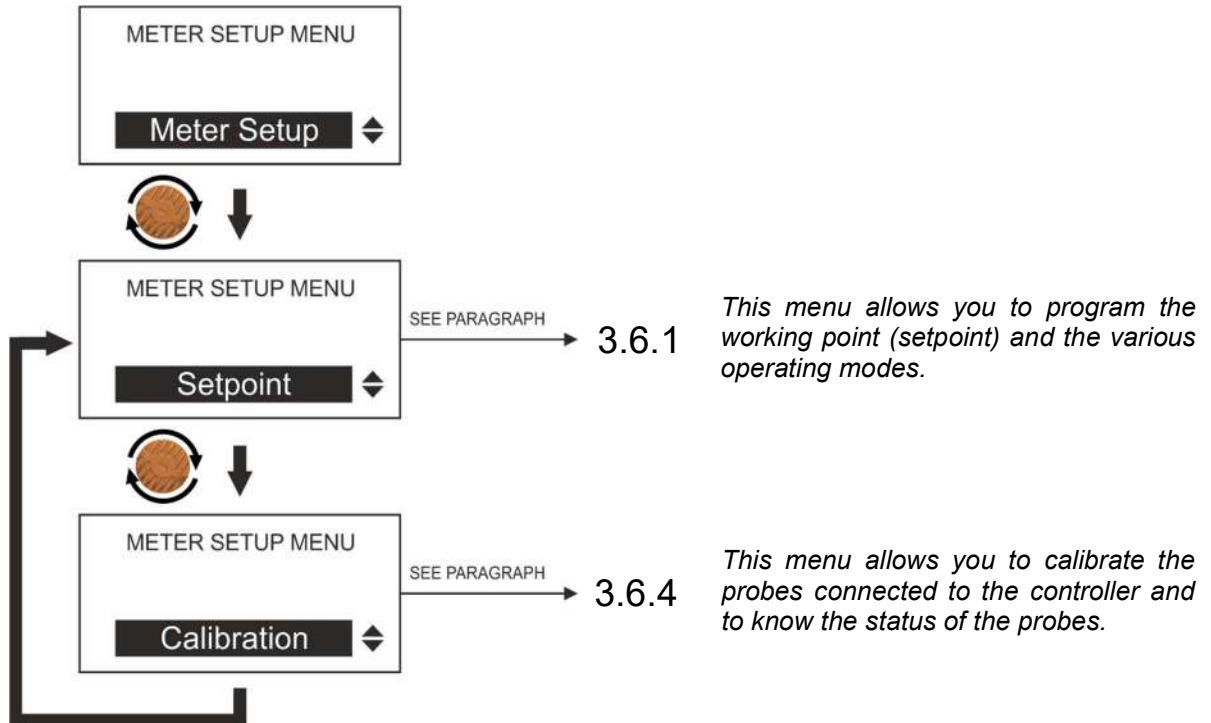

3.6.1 SETPOINT menu (BASIC menu)

This menu programs the relay outputs OUT1... 4 relating to pH, to Redox and Chlorine. The **ON-OFF** mode adjusts the controller so that it works using two set values that enable or disable the dosage.

Here are the steps to set up this feature:

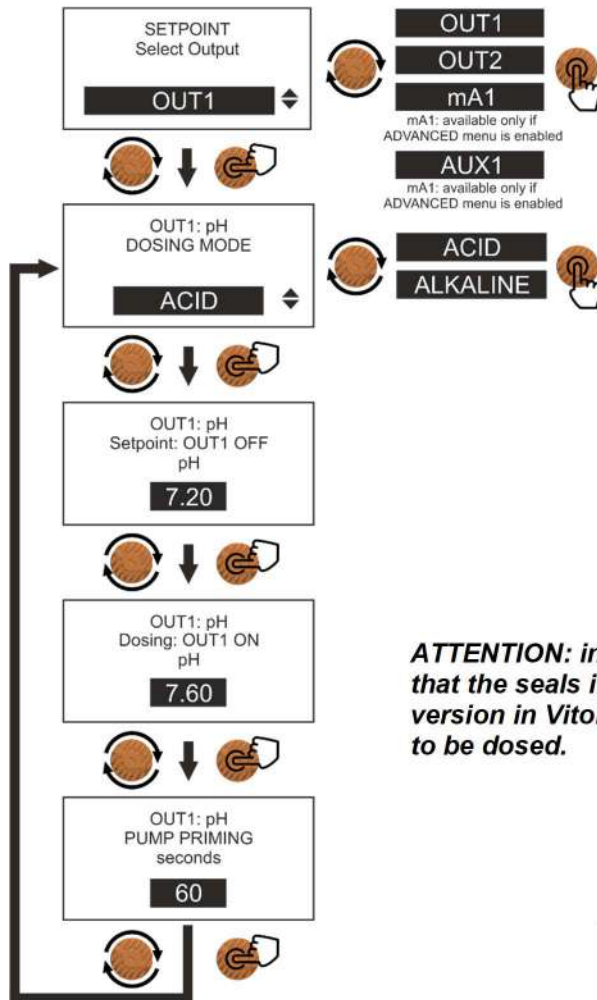

The **CH1** channel for pH measurement has two independent outputs, **OUT1** and **OUT2** which can be used to connect up to two dosing systems for two different types of chemical products (e.g. acid dosage and alkaline dosage) or as a backup system for dosing aid or for any damage to one of the two pumps.

Example: dosing mode ACID on OUT1:
 Setpoint: **7.20pH** (pump is OFF)
 Dosing: **7.60pH** (the pump is ON);
 For values equal to or lower than the Setpoint, the pump does not work;
 For values equal to or greater than 7.60 pH, the pump is turned on.
 It is also possible, once the controller has been programmed, to enable the priming of the pump connected to it (this operation can also be skipped).

ATTENTION: in the case of dosing an Alkaline chemical verify that the seals in the pump body of the dosing pump (standard version in Viton®) are chemically compatible with the product to be dosed.

Redox setting

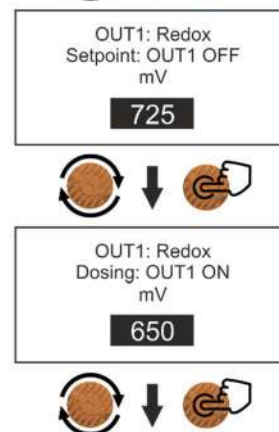
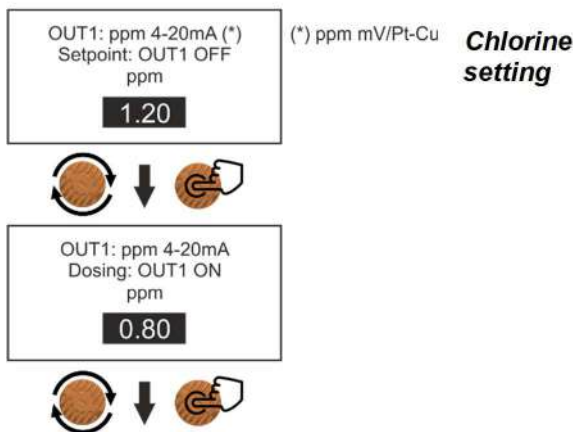
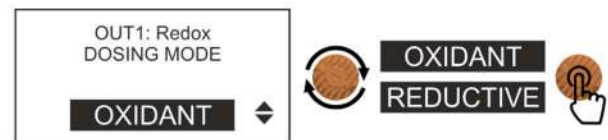

3.6.2 SETPOINT menu (ADVANCED menu)

This menu appears only if the ADVANCED has been enabled from the settings menu and the measurement channel has been set in mA mode instead of ON-OFF (default).

Here are the steps to set up a pH measure but the rule also applies to Redox and Chlorine:

pH setting

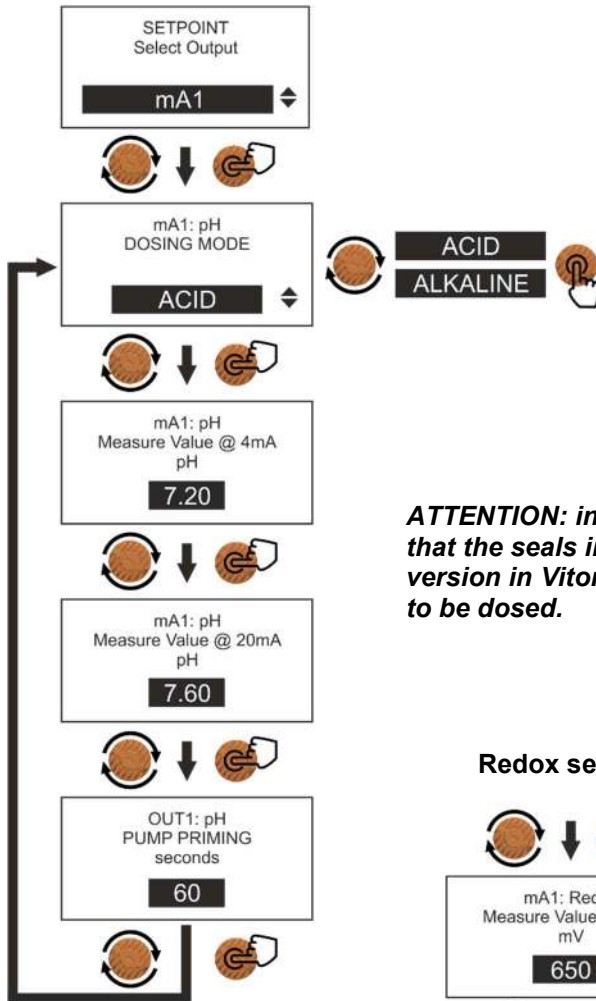

The mA mode allows you to set a working point (Setpoint) and to program the dosage of a proportional dosing pump (such as HC151 + PIMA or HC151 + MULTI) connected to the mA output of the instrument according to the value of the measurement read.

Example: dosing mode **ACID** enabled:
 Measured value at 4mA: **7.20 pH**;
 Measured value at 20mA: **7.60 pH**;
 For values equal to or less than 4mA the dosing pump doesn't work;
 For values equal to 20mA the dosage is carried out at the maximum frequency which decreases as the 4mA approaches;
 It is also possible to enable the priming of the connected pump (this operation can also be skipped).

ATTENTION: in the case of dosing an Alkaline chemical verify that the seals in the pump body of the dosing pump (standard version in Viton®) are chemically compatible with the product to be dosed.

Redox setting

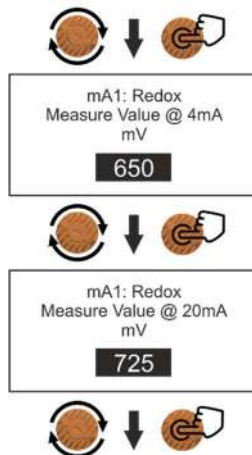

Chlorine setting

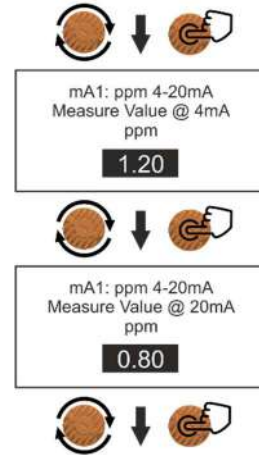

3.6.3 SETPOINT menu Temperature (ADVANCED menu)

It is also possible to set a Setpoint on the measurement of temperature when you want to control a heater (e.g. for heating the water of a swimming pool); the activation of this function implies having a 3 or 4 wires PT100 temperature sensor.

Here are the steps to set up this feature:

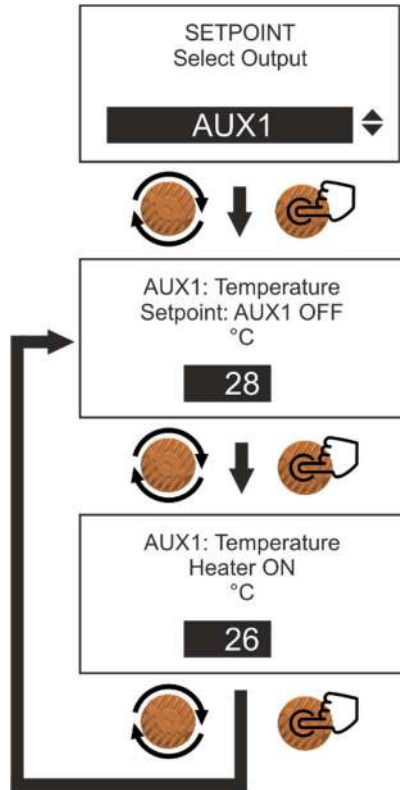

Setpoint: AUX1 OFF
Set the ideal temperature
(Eg.: 28°C)

Heater ON
Set the minimum temperature
(Eg: 26 ° C) to activate the heater.

3.6.4 CALIBRATION menu

In order to obtain a precise measurement of the chemical-physical parameters of the water of the plant to be treated, it is necessary, during the start-up, to calibrate the probes (pH, Redox or Chlorine).

pH probe calibration

For proper calibration follow the steps described below:

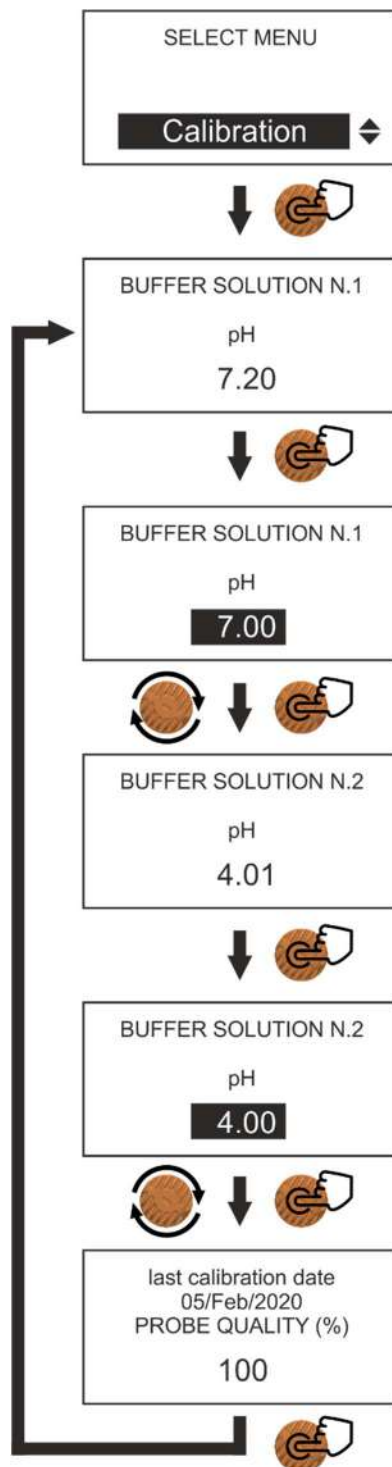

To calibrate the pH electrode, you need two buffer solutions, one at pH 7 and the other at pH 4 or pH 9.

It would be important to measure the temperature of the buffer solution and check the corresponding value on the label of the solution itself; if this measurement cannot be made, skip this step and proceed to the next;

Connect the BNC connector of the electrode to the relative input on the controller;

Remove the protective cap of the electrode then wash it with water and dry it;

Enter in Calibration menu and follow the instructions on the display: dip the electrode in the first buffer solution at pH 7, wait for the measurement to stabilize, if necessary, modify the value read on the display with one on the solution (it can happen that the measurement does not correspond perfectly to the solution, this is perfectly normal). Press on the encoder to confirm this value;

Remove the electrode from the first solution and wash it with water, dry it then dip in the second buffer solution at pH 4 (or pH 9); wait for the measurement to stabilize, if necessary, modify the value read on the display with the one on the solution. Press on the encoder to confirm the value;

At the end of the procedure, the quality of the electrode will be shown on the display.

For values between 25% and 0% we suggest replacing the electrode.

Redox probe calibration

For proper calibration follow the steps described below:

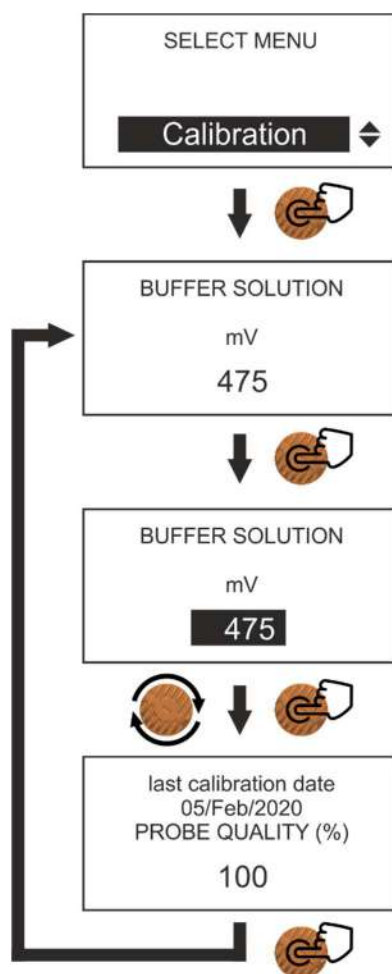

To calibrate the Redox electrode it is necessary to have a buffer solution with a known value (for this example the **475mV** solution was used).

Connect the BNC connector of the electrode to the relative input on the controller;

Remove the protective cap of the electrode then wash it with water and dry it;

Enter in Calibration menu and follow the instructions on the display: dip the electrode in the **475mV** buffer solution, wait for the measurement to stabilize, if necessary, modify the value read on the display with the one on the solution (it may happen that the measurement does not correspond perfectly to solution, this is perfectly normal). Press on the encoder to confirm this value;

At the end of the procedure, the quality of the electrode will be shown on the display.

For values between **25%** and **0%** we suggest replacing the electrode.

Chlorine probe calibration

For a correct calibration follow the steps described below:

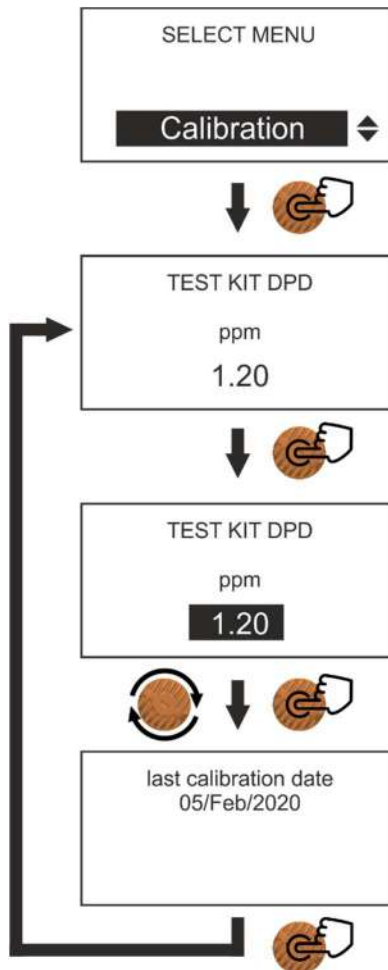

To calibrate the Chlorine probe it is necessary to have a **photometer** and a **DPD test kit**.

ATTENTION: for the membrane chlorine probe (ppm-mV or ppm-mA) follow the probe manufacturer's instructions for the mandatory preliminary operations before being able to connect it to the pump;

Connect the probe wires to the relative input of the controller (refer to the image in paragraph 3.2 and the table in paragraph 3.3 to identify its position and how to connect it);

Install the probe inside the modular probe holder and regulate the flow of water with a constant flow rate of not more than 60 l / h and not less than 30 l / h;

Wait for the polarization of the probe (this can also take several hours: from 1 to 24), the probe manufacturer suggests to wait up to 6 hours before performing the calibration;

ATTENTION: if the Pt-Cu probe is used to determine the free chlorine, the polarization times are reduced to about 2 hours.

Access the Calibration menu and follow the instructions on the display: take a water sample and use the DPD test kit and photometer to determine the Chlorine value, modify the value read on the pump display with the value detected by the photometer. Press on the encoder to confirm this value;

3.7 CORRELATION BETWEEN FREE CHLORINE, pH e REDOX

The graph shown below is useful for understanding the correlation between the measurement of free Chlorine the pH and Redox. In a swimming pool system this information is very useful to verify that there is an "alignment" of all the measures to ensure that the chemical-physical parameters are respected; to better understand the graph, a typical example is described:

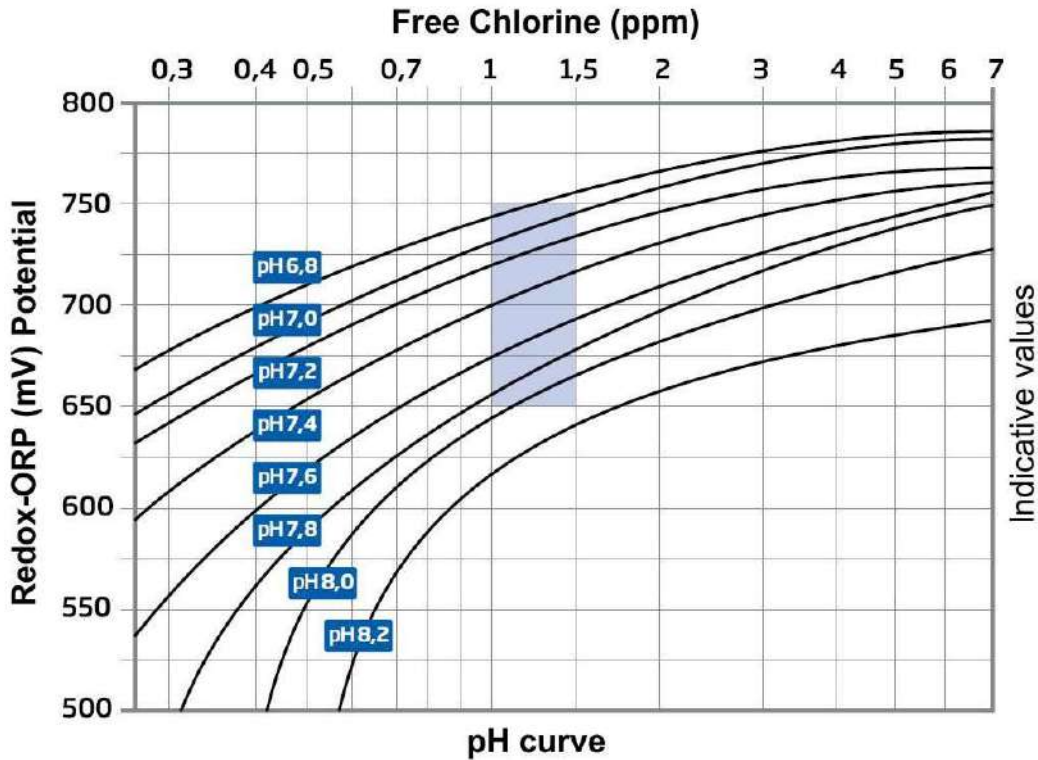

The area highlighted in light blue is the one that indicates the ideal values in a swimming pool system. For example: for pH value of 7.2 (ideal), a Redox value of 725mV corresponds, corresponding to a free Chlorine value of 1.2ppm.

3.8 GENERAL / ADVANCED SETTINGS and SECURITY

The settings menu is divided into three main categories: **General**, **Advanced** (only if enabled) and **Security**: in General Settings you will find the basic settings encountered during the start-up process. In the Advanced Settings it is possible to enable some hidden functions, divided by measuring channels (CH1 = Channel 1), such as the mA outputs, the Auxiliary outputs (AUX), etc.

In the Security settings, on the other hand, alarms can be set, a password can be chosen to protect against unauthorized access, etc.

Below is a navigation diagram of the Settings:

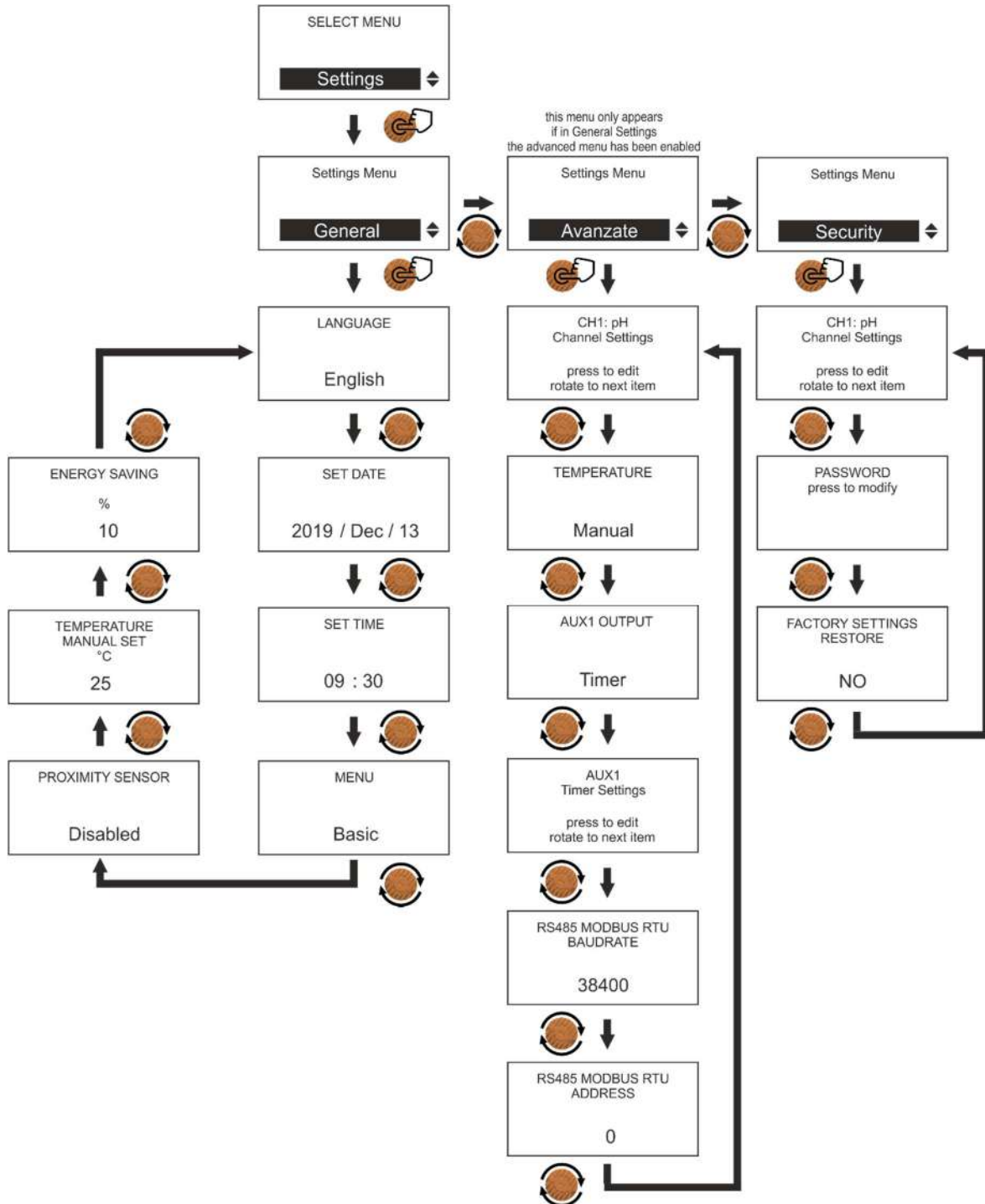

The various functions are described in the following paragraphs; the date, time and type of language settings are self-explanatory and have already been addressed in paragraph 3.4.

3.8.1 General > Proximity sensor

This function allows you to enable / disable the proximity sensor (not supplied with the controller) which provides, if enabled, the presence or not of water inside the modular electrode holder (which it needs to operate correctly, of the correct flow rate). If there is no flow of water or if this is not in a correct value, the alarm message "NO FLOW" will appear on the display; the activation of this alarm will immediately stops the dosage of the dosing pumps connected to the controller. For the correct connection of the sensor to the controller, refer to the diagram in paragraph 3.3. Here are the steps to set up this feature:

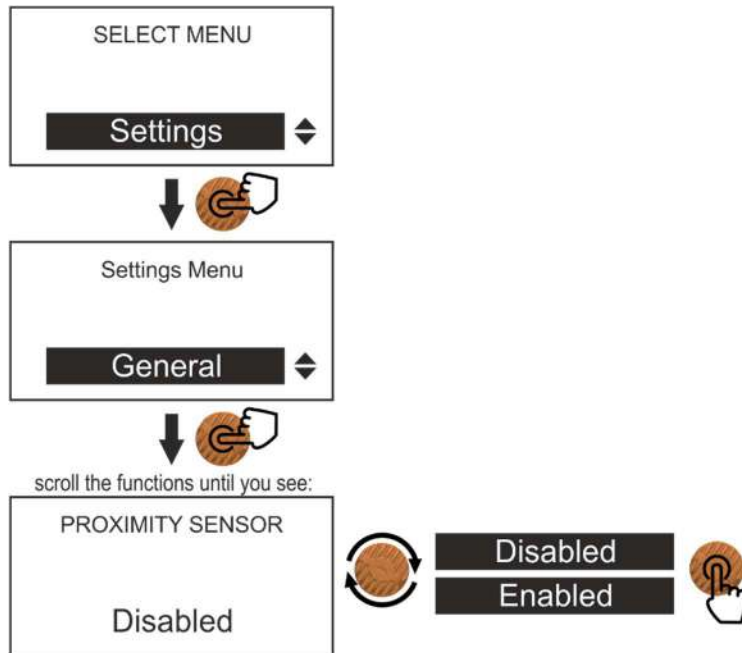

3.8.2 Generali > Temperatura manuale

This function allows you to manually set the water temperature. Since the pH of the water in a plant is also influenced by its temperature, there is the need to "compensate" for any variations in the measurement as a function of the detected temperature. Here are the steps to set up this feature:

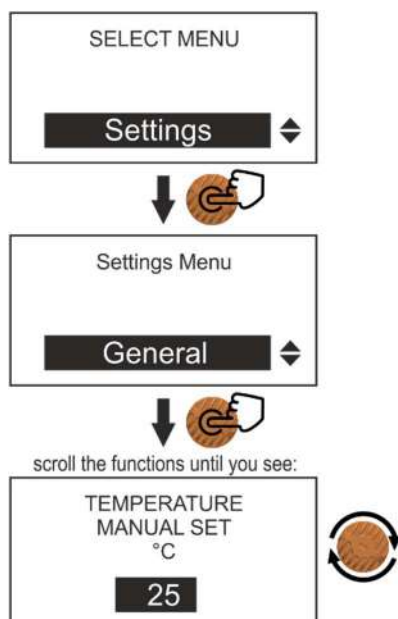

3.8.3 General > Energy saving

It is possible to reduce the brightness of the display during its normal operation to limit current absorption and to protect the display from overheating and therefore increase its longevity. Therefore, the brightness can be modified from 100% (maximum brightness) to 10% (minimum brightness); once the value has been chosen, the display will decrease its brightness if, after 1 minute, the controller is not touched. Whenever you act on the encoder, the maximum brightness is restored and then returns to energy saving after 1 minute. Here are the steps to set up this feature:

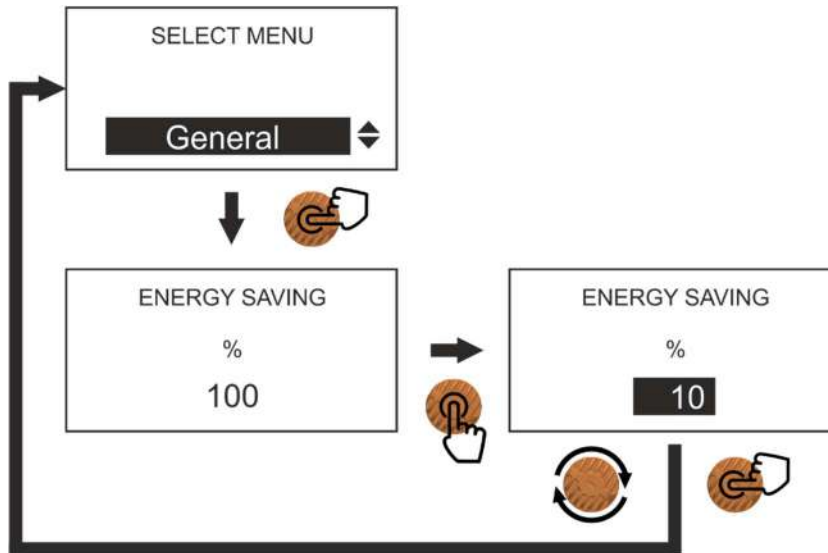

Attention!!! The use of the functions, described in the following paragraphs, must only be carried out by expert personnel, we decline any responsibility for any damage caused to people and / or things due to incorrect use.

3.8.4 Advanced > Channel measurement settings

The controllers are designed to connect different types of probes: for measuring the pH, the oxide-reduction potential (ORP) and for determining the value of free chlorine or other chemical products that are measured in ppm or in mg / l (1 ppm = 1 mg / l).

Here are the steps to select the correct probe:

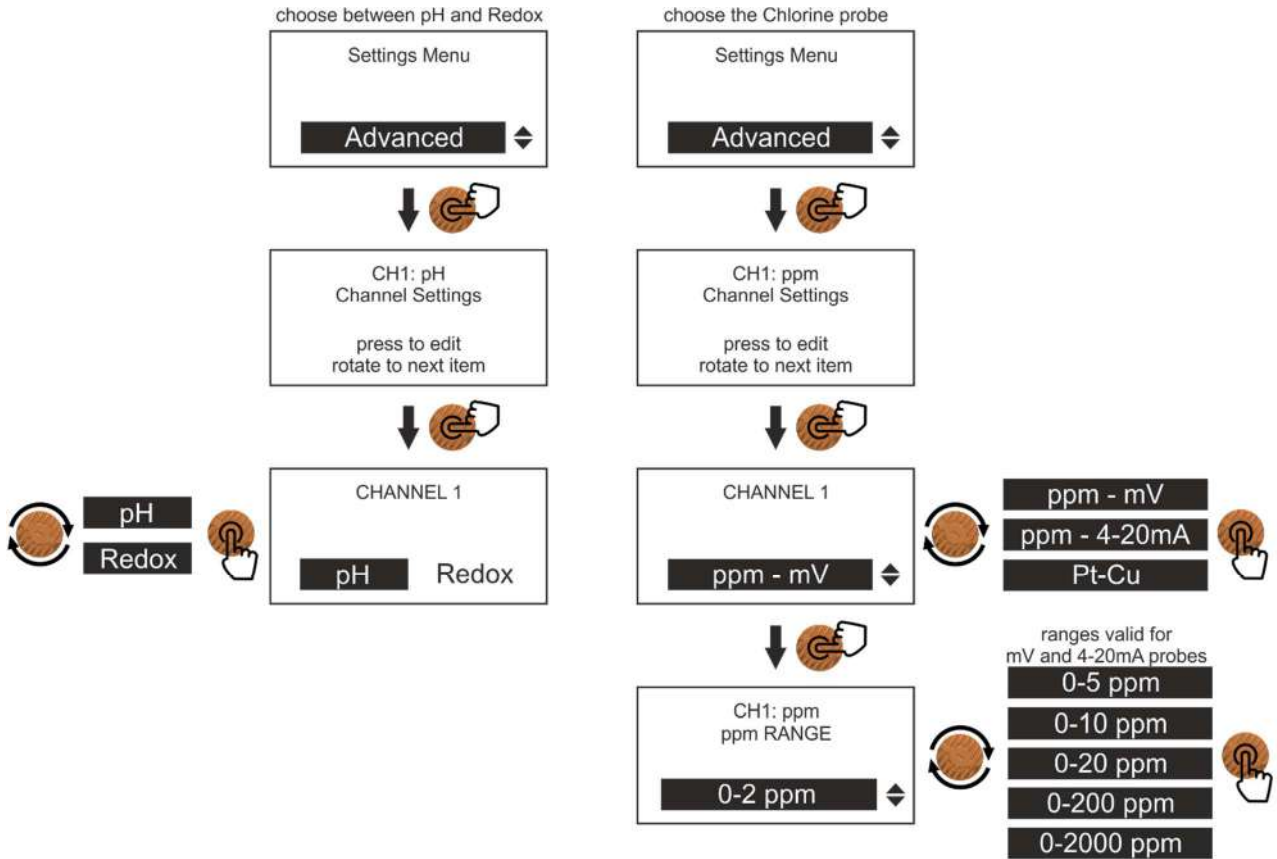

3.8.5 Advanced > pH priority

pH measure always has priority. This means that the dosage of the disinfectant remains inhibited until the pH value set is reached or restored. Only then will the dosage of the disinfectant be enabled by the controller.

An excellent pH value present in the water guarantees the maximum production of strong oxidant and therefore a high efficiency in disinfection and an optimization in the consumption of chemical product.

Here are the steps to set up this feature:

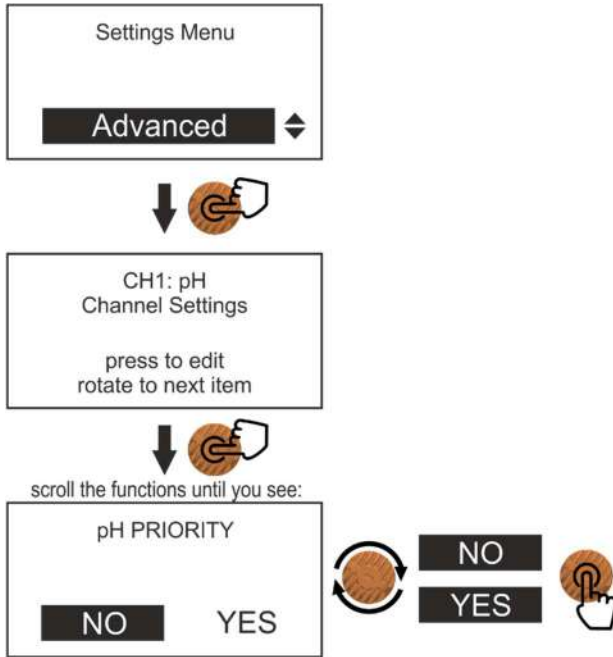

3.8.6 Advanced > Stabilization time

Before you can make correct measurements, the probes must first polarized. If dosing started during the polarization you would risk to inject chemicals based on incorrect data.

This function allows you to set a time (in minutes or seconds), following the calibration of the probe, which allows it to polarize correctly; during this time the dosing is inhibited.

Here are the steps to set up this feature:

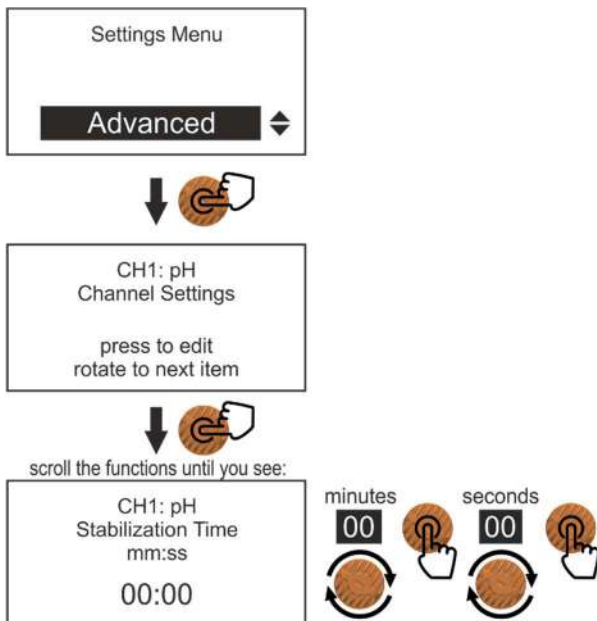

3.8.7 Advanced > mA Output

Controllers are equipped with mA outputs which allow to associate current values (4 and 20mA) to measured values of pH, Redox and Chlorine.

For the correct connection of external devices to the controller, refer to the diagram in paragraph 3.3.

Here are the steps to set up this feature:

The example describes the pH measurement but the rule is also valid for Redox and Chlorine.

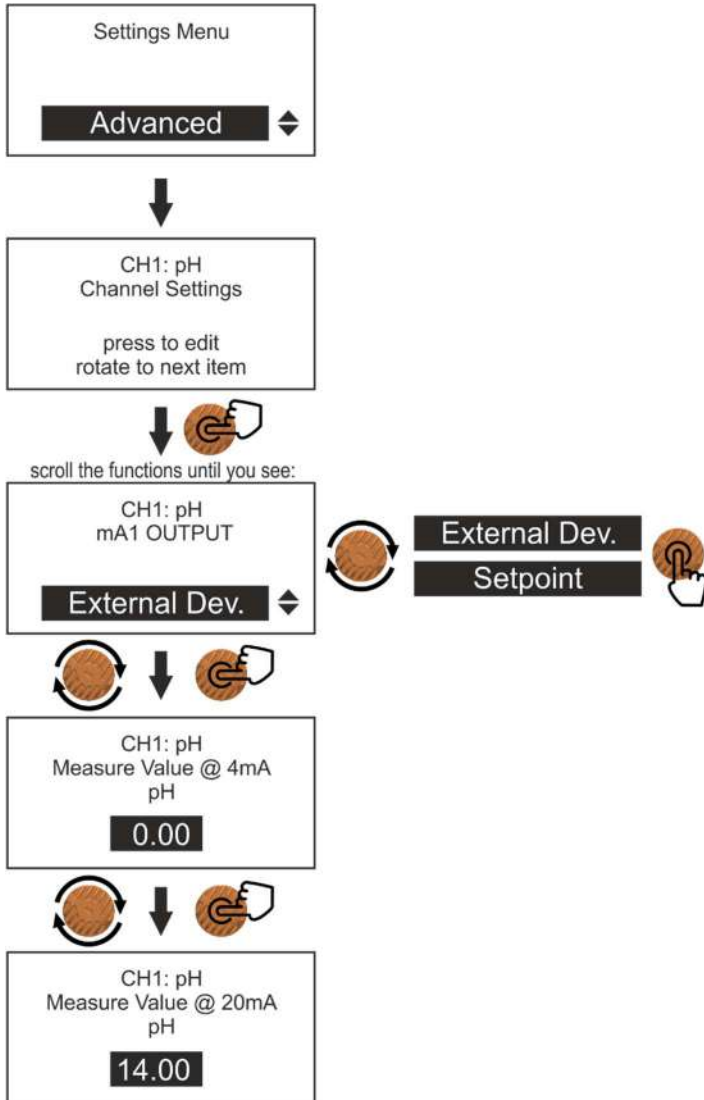

If you want to connect the mA output to devices capable of receiving a current signal (e.g. PLC for process control or data logger acquisition cards connected to a PC), choose the **External Dev.** option from the selection menu.

If you want to connect a dosing pump equipped with a proportional input (HC151 + PIMA, HC151 + MULTI), then choose the **Setpoint** option from the selection menu and set the parameters in the "Meter setup" menu (see paragraph 3.6.2 for details).

Associate a pH value (Redox or Chlorine) with the current value of 4mA.

Associate a pH value (Redox or Chlorine) with the current value of 20mA.

3.8.8 Advanced > Temperature sensor

This menu allows you to enable the PT100 temperature sensor (not included with the controller). When enabled, it compensates the pH value read and can also be used to adjust the water temperature of a swimming pool (see paragraph 3.6.3 for details).

For the correct connection of the sensor to the controller, refer to the diagram in paragraph 3.3. Here are the steps to set up this feature:

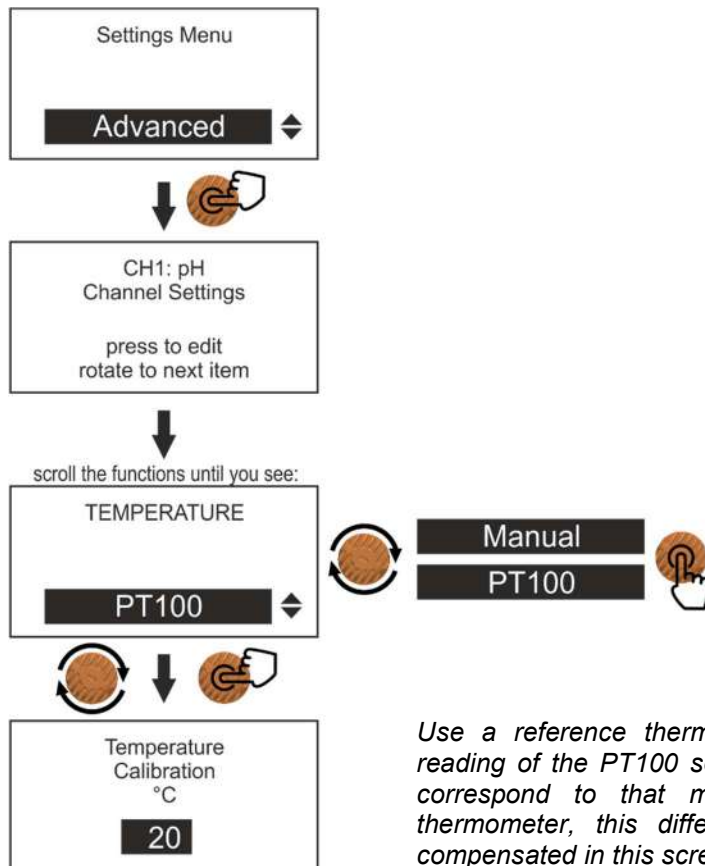

Use a reference thermometer, if the reading of the PT100 sensor does not correspond to that made with the thermometer, this difference can be compensated in this screen.

3.8.9 Advanced > Auxiliary Output (AUX)

The controllers are equipped with auxiliary relay outputs (AUX) which can be programmed to perform various functions:

- It can be used as a daily / weekly timer to activate any device (which does not exceed a max resistive load of 5A at 240V) such as, for example, a pump for dosing the flocculant, the lights of a swimming pool or irrigation system in a private garden;
- It can be used for the **cleaning** function of the Pt-Cu cell (Chlorine version only);
- It can be used to control a heater (e.g. for heating the water in a swimming pool), the activation of this function implies having a PT100 temperature sensor.

Here are the steps to enable this feature:

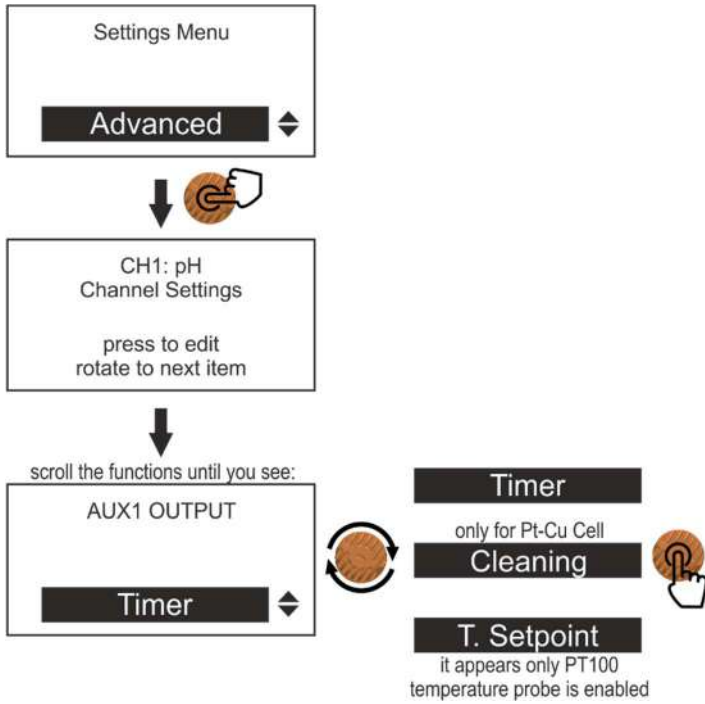

If the "Timer" mode is chosen:

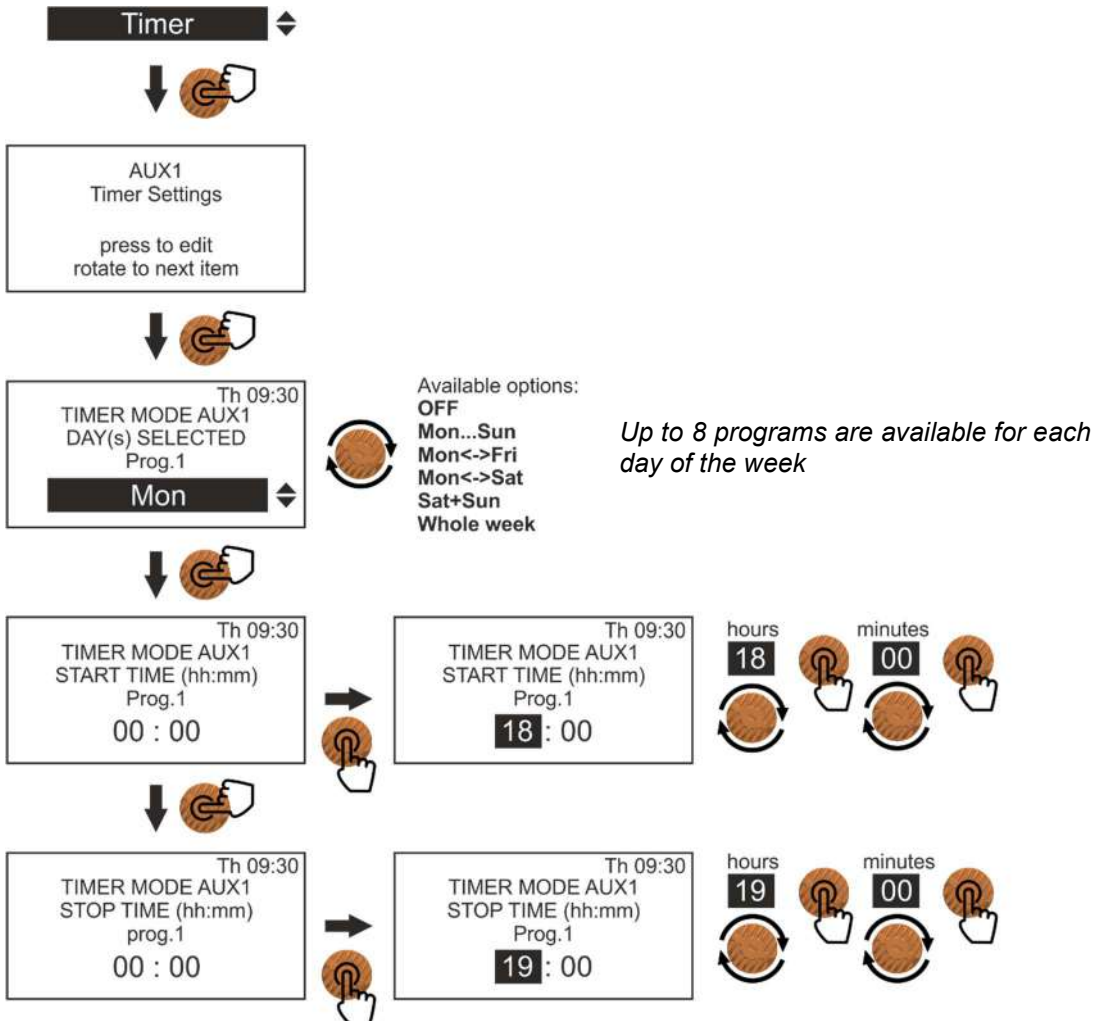

If the "Cleaning" mode is chosen (Pt-Cu only):

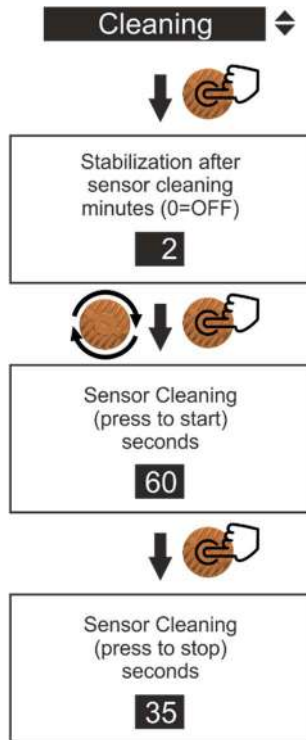

Set the stabilization time of the chlorine measurement once the Pt-Cu cell cleaning phase is completed (max 60 minutes).

Set the cleaning time of the Pt-Cu cell (max 60 seconds).
Attention: during this process all controller outputs and all measure are frozen.

Cleaning can be stopped at any time by pressing the encoder.

If the "T. Setpoint" mode is chosen, follow paragraph 3.6.3

3.8.10 Advanced > RS485 serial interface

The controller has an RS485 serial port that can be used as remote control, for example using a PLC or a Personal Computer or even a BMS.
 Here are the steps to set up this feature:

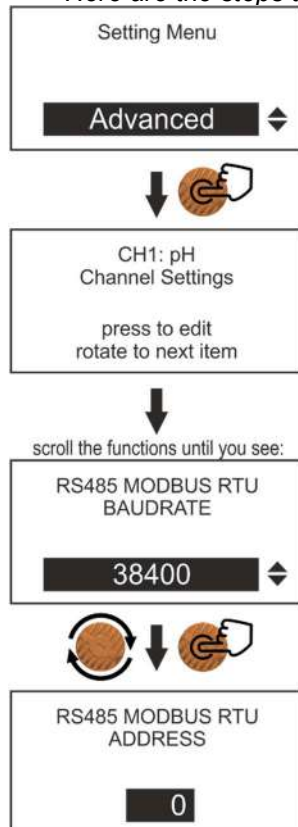

This serial port supports the MODBUS RTU standard protocol widely used in the industrial sector.
 For specifications see: <http://www.modbus.org/>

The Baud rate menu item is used to set the communication baud rate of the RS485 serial port connected to the controller.

For the list of internal registers of the instrument, contact FG Pumps

3.8.11 Security > Low Level Delay

With this function it is possible to delay the deactivation of a metering pump following the activation of the level sensor.

When this function is active, and the level of chemical inside the tank reaches the minimum, the level alarm is activated on the controller (on the display, "**Low Tank ALL.**" Appears) but the metering pump continues to dose for the set time, after this time the dosage stops.

When using the "LAFL" type suction lance, the activation of this function is suggested, which allows you to continue dosing and at the same time to prepare a new tank or to fill the old one with the chemical product. This ensures better continuity of dosage.

ATTENTION: this function must be activated only if you are using the suction lance with the LAFL safety margin type (see photo below).

Next are the steps to set up this function:

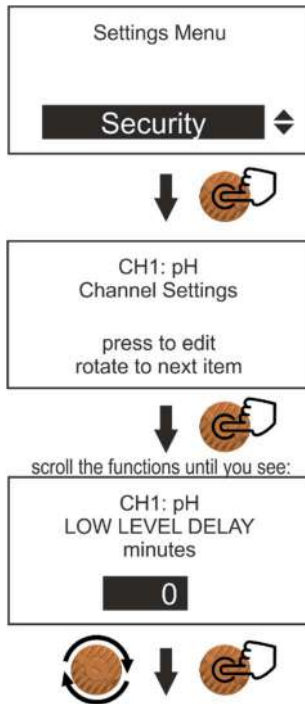

FGFL

It is possible to set a delay in minutes according to the size of the tank in use and the quantity dosed by the pump.

3.8.12 Security > Level Input Polarity

It is possible to invert the polarity of the level sensor connected to the controller from Normally Open (N.A.) to Normally Closed (N.C.) and vice versa.

Here are the steps to set up this feature:

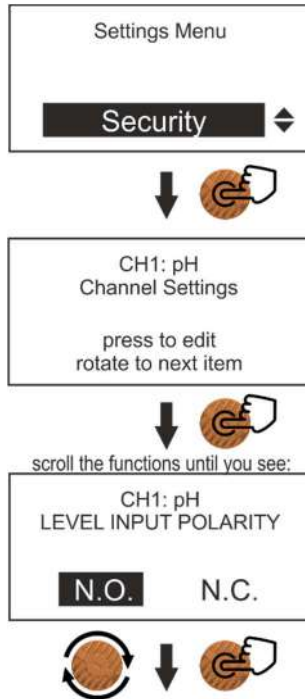

3.8.13 Security > Minimum / Maximum value alarm

It is possible to set an alarm threshold for minimum and maximum measurement values (the alarm does not deactivate the dosage, to reset alarm simply touch the encoder and restore parameters).

Here are the steps to set this function on the pH measurement, but the rule also applies to the Redox and Chlorine measurements:

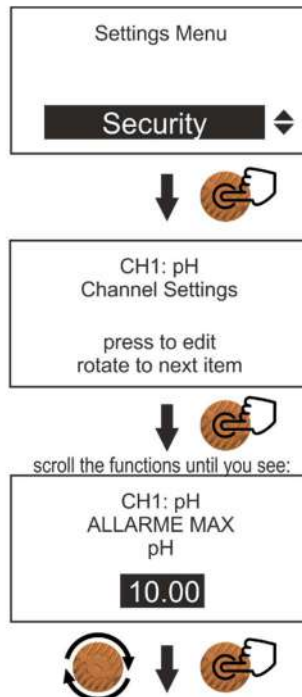
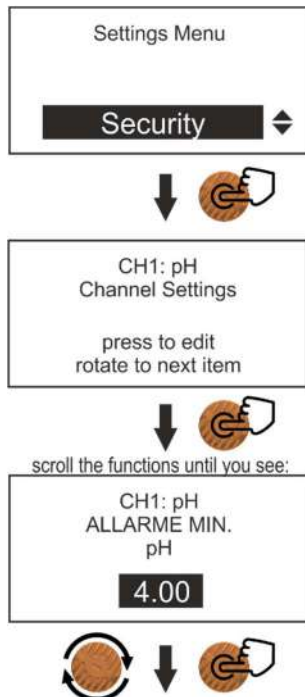

3.8.14 Security > (OFA) Over Feed Alarm

This function, when activated, stops the dosage of a dosing pump after the set time, if at this time is never reached the setpoint.

To restore operation, manual intervention is required on the controller. The value "0" corresponds to function disabled.

Here are the steps to set up this feature:

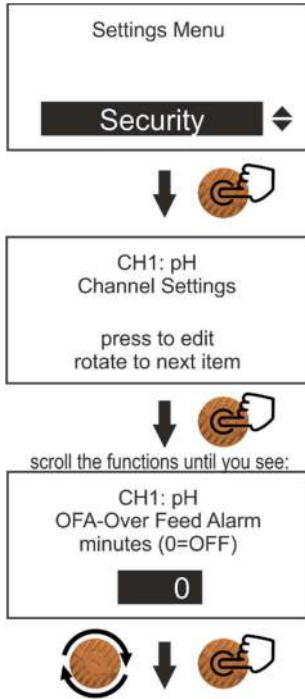

3.8.15 Security > Password

It is possible to set a security password to prevent unauthorized access to the controller configuration menus. **If the user forgets or loses his password, he must contact our Assistance.**

Here are the steps to set up this feature:

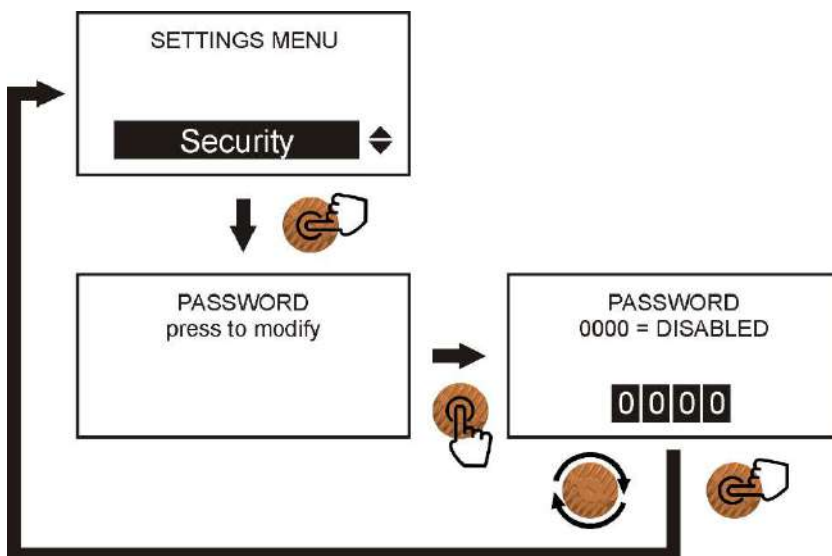

3.8.16 Security > Factory Settings restore

It is possible to restore the controller parameters to factory settings using this function.

ATTENTION: this will delete all previously set data and all statistics.

Here are the steps to set up this feature:

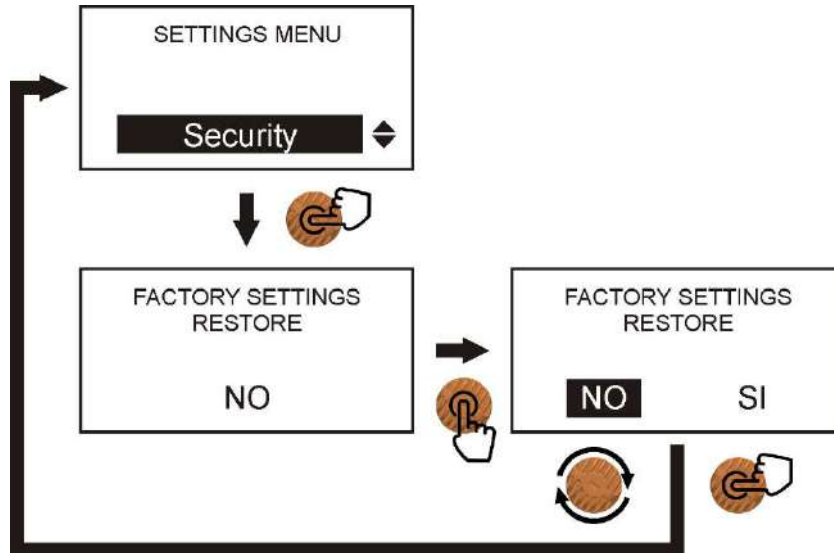

3.9 STATISTICS

During the normal operation of the controller operating data is stored; these data can be viewed within the "STATISTICS" menu.

Here are the steps to set up this feature:

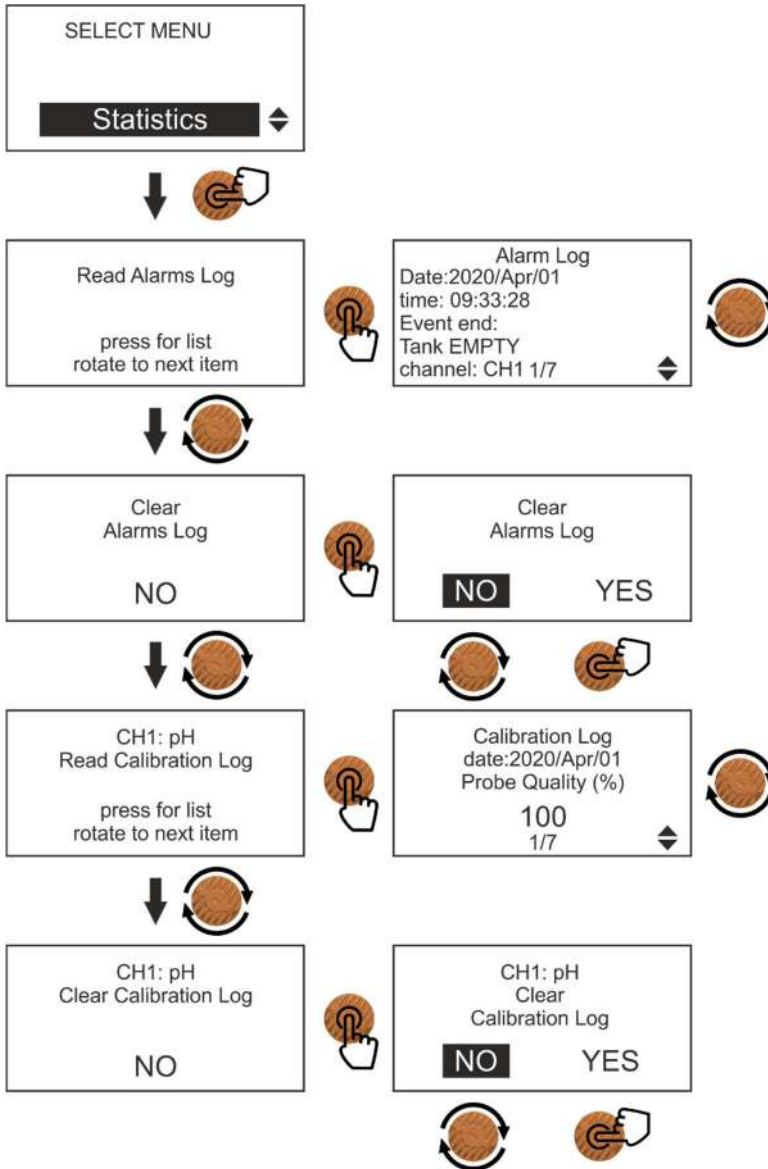

The alarm history shows all the events occurred during the operation of the controller; information about the event is shown (when it occurred and what caused it). The alarms are shown on multiple pages and the list always starts showing the most recent.

It is possible to delete all the alarms from the controller's memory.

The calibration history shows all the calibrations of the probes carried out; only the last 10 calibrations are shown over a period of 2 months from the first calibration. If several calibrations are carried out on the same day, only the most recent one will be shown.

It is possible to delete the history of all calibrations divided by measurement channel from the controller's memory.

3.10 WARRANTY

The product is covered by the manufacturer's warranty for manufacturing defects. The methods and conditions are set forth in the "General Conditions of Sale" document.

TABELLA RIEPILOGATIVA FUNZIONI / FUNCTION SUMMARY TABLE

SETUP MISURA (Par. 3.6)	IMPOSTAZIONI (Par. 3.8)			STATISTICHE (Par. 3.9)
	Generali	Avanzate	Sicurezza	
Setpoint (Par. 3.6.1)	Lingua	Priorità pH (Par. 3.8.5)	Ritardo All. Livello (Par. 3.8.11)	Storico allarmi
Calibrazione (Par. 3.6.4)	Impostazione data	Stabilizzazione (Par. 3.8.6)	Polarità Ingr. Livello (Par. 3.8.12)	Storico calibrazione
	Impostazione orario	Uscita mA (Par. 3.8.7)	Allarmi Min/Max (Par. 3.8.13)	
	Menu base/Avanzato	Sens. Temperatur. (Par. 3.8.8)	All. dosaggio (OFA) (Par. 3.8.14)	
	Sensore prossimità (Par. 3.8.1)	Uscita Ausiliaria (Par. 3.8.9)	Password (Par. 3.8.15)	
	Temperatura manuale (Par. 3.8.2)	Porta RS485 (Par. 3.8.10)	Ripristino Parametri (Par. 3.8.16)	
	Risparmio energetico (Par. 3.8.3)			

METER SETUP (Par. 3.6)	SETTINGS (Par. 3.8)			STATISTICS (Par. 3.9)
	Generali	Avanzate	Sicurezza	
Setpoint (Par. 3.6.1)	Language	pH priority (Par. 3.8.5)	Low Level Delay (Par. 3.8.11)	Alarms Log
Calibration (Par. 3.6.4)	Set Date	Stabilization time (Par. 3.8.6)	Level input polarity (Par. 3.8.12)	Calibration Log
	Set Time	mA output (Par. 3.8.7)	Min/Max Alarms (Par. 3.8.13)	
	Basis/Advanced Menu	Temperature sens (Par. 3.8.8)	OFA over feed alarm (Par. 3.8.14)	
	Proximity sensor (Par. 3.8.1)	Auxiliary output (Par. 3.8.9)	Password (Par. 3.8.15)	
	Manual Temperature (Par. 3.8.2)	RS485 port (Par. 3.8.10)	Factory settings (Par. 3.8.16)	
	Energy Saving (Par. 3.7.5)			



FG PUMPS
METERING PUMPS FOR
CHEMICALS

***INSTRUCTIONS MANUAL
FOR CONTROLLERS SERIES:***

D100, D200, D300



ALLIGUARD
WATER TREATMENT SOLUTIONS

Lasithiou 77, Glyfada Athens, Greece 16674
M: 6947 810 227 • 6906 185 915 / E: grakanidis@alliguard.gr
www.alliguard.gr